

Combination Closed Loop and V_{CC} Power Control for a GSM/GPRS PA

By Paul McCambridge, Xindium Technologies, and Brian Whitaker, Maxim Integrated Products

This application note describes the use of two manufacturers' ICs in a GSM/GPRS power control system that controls DC voltage as well as RF drive

Power control is an important performance specification for GSM/GPRS wireless handsets. This article shows how the MAX4002 low-cost, low-power logarithmic amplifier and

power detector, and the XIN9133 quad-band GSM/GPRS power amplifier (PA) are combined in a closed loop power control system with the added advantage of PA protection through supply voltage power control. This results in significant advantages over today's predominant GSM power control solutions on the market.

Power Control Requirements

Important requirements for power amplifiers in a GSM cell phone are:

- Adjustable and precision-set output power.
- The PA is not allowed to transmit outside its frequency band (a precise power ramp control is needed to eliminate out-of-band noise).
- The PA is only allowed to transmit in its own timeslot, not in others (requiring tight ramp control).

When a PA is used without control, it is difficult to meet the GSM specifications, because the PA by itself is not accurate enough. Reasons for inaccuracy include:

- The PA is a non-linear device.
- The PA gain and output power varies with frequency, battery voltage and temperature.
- Gain control slopes of PAs vary across device populations.

There are several key advantages that are a direct result of the unique implementation in this note. Some of them are:

- Minimized power variation vs. supply voltage
- Minimized power variation vs. frequency
- Minimized power variation vs. temperature
- Maximized PA ruggedness vs. load impedance fluctuation
- Maximized loop stability
- Minimized loop bandwidth variations across power levels
- Minimized burst timing and transient spectrum tradeoffs

By combining the XIN9133 with the MAX4002 (Figure 1), this closed loop implementation allows for very tight output power control. The MAX4002 continuously samples the output power of the XIN9133 and maintains the output power to within a very narrow range, independent of the output power load, power supply and temperature fluctuations. Typically, output powers can be maintained to within tenths of 1 dB. This gives the handset manufacturer much better control over their output power settings. The GSM specification calls for 'typical' and 'minimum' output power requirements for the handset. With tight control on output power settings the handset manufacturer has increased options in handset performance. In calibration, if desired, the manufacturer could set the output power near the low end of the power range and thereby significantly extending the talk time of the handset.

The second advantage of this architecture is improved device ruggedness. The PA in a

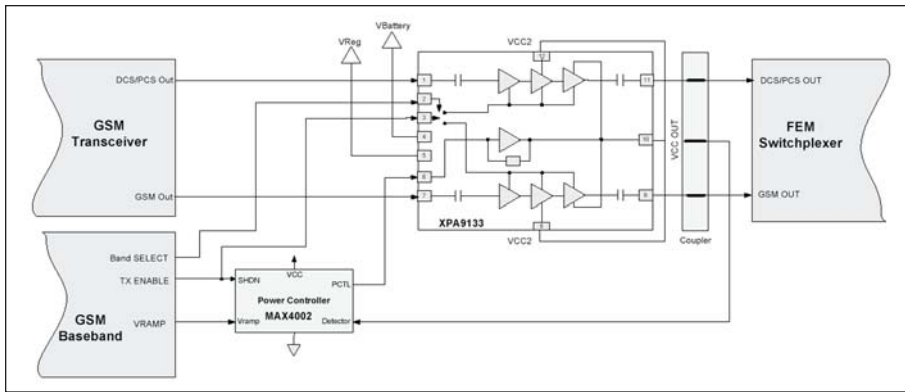

Figure 1 · System block diagram.

handset is connected more-or-less directly to the antenna. As a result, the PA can see extremely wide load fluctuations during operation. Under these load conditions, using open loop power control, the PA output power can increase by as much as 3 dB, which is not good for current drain, thermal cycling or device reliability. Additionally, the supply voltage in the phone has a very wide range over which it must work (2.9 to 5.5 V). This puts stress on the PA device since the combination of high voltage and low load impedance put the device into a high current consumption situation. The XIN9133 employs V_{CC} power control which regulates the voltage level applied to the PA, limiting stress on the device.

Theory of Operation

PA output power can be controlled by varying V_{CC} . Many power control systems in GSM sense either forward power or collector/drain current. In the XIN9133, a high-speed control loop is incorporated to regulate the collector voltages of the amplifier while the stages are held at a constant bias. The supply voltage to the PA is regulated to a maximum voltage of 3.6 V, greatly reducing the stress on the device under mismatched.

The basic V_{CC} control circuit is shown in Figure 2. By regulating the power, the stages are held in saturation across all power levels. As the required output power is decreased

from full power, the collector voltage is decreased. This regulation of output power is demonstrated in Equation 1 where the relationship between collector voltage (V_{supply}) and output power is shown.

$$P_{dBm} = 10 \log \left[\frac{(2V_{supply} - V_{sat})^2}{8R_{load} \times 10^{-3}} \right] \quad (1)$$

The XIN9133's internally regulated collector voltage has a two-fold effect. It eliminates one of the two key contributors to output power variation while also limiting the maximum supply voltage on the device, protecting the output stage from over-current. Load impedance and supply fluctuations are the dominant contributors to output power variations.

There are many other advantages to the XIN9133 architecture. In conventional architectures the PA gain (dB/V) varies across different power levels, and as a result the power control loop bandwidth also varies. With some PAs it is possible for the gain (control slope) to change from 100 dB/V to as high as 1000 dB/V. The challenge in this scenario is keeping the loop bandwidth wide enough to meet the burst mask at low slope regions, but prevent loop instability at high slope regions.

The XIN9133 architecture combined with the MAX4002 solves the loop instability problem, because the

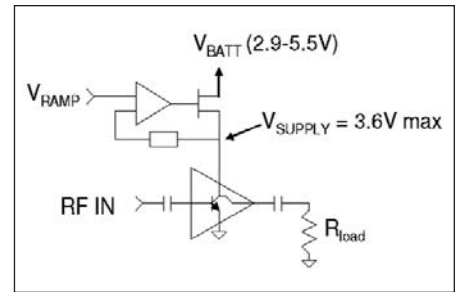

Figure 2 · Basic V_{CC} power control circuit.

PA gain is more consistent by using V_{CC} power control. The XIN9133 loop bandwidth is determined by the bandwidth of the internal control circuitry and the RF output load and does not change with respect to power levels. This makes it easier to maintain loop stability with a high bandwidth loop since the bias voltage and collector voltage do not vary.

One problem in a control loop is that a delay within the loop decreases the loop's stability as well as affects the burst timing. Varying input power from the VCO with respect to temperature, frequency or supply voltage is one source of this type of problem. If the VCO power changes, the loop gain changes which affects the loop bandwidth. The burst timing can shift especially at low power levels. The XIN9133 is insensitive to a change in input power and the burst timing is constant and requires no software compensation. Switching transients occur when the up and down ramp of the burst is not smooth. Controlling the output power by changing the collector voltage ensures a smooth control slope. All stages are kept constantly biased, also removing inflection points.

Principle of a PA Control Loop

The benefit of a PA control loop is its immunity to changes in the PA's gain. The block diagram in Figure 3 shows how a PA control loop works. Any temperature dependency in the gain control function of the PA or load fluctuations will be eliminated

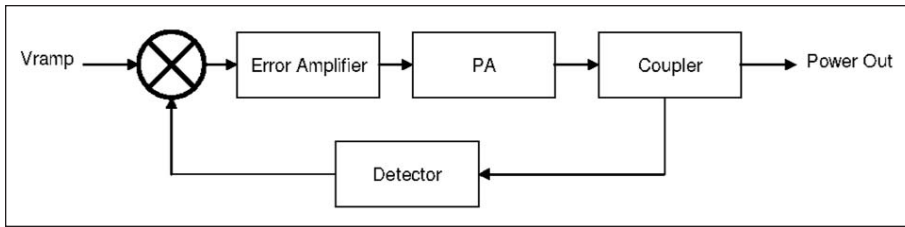

Figure 3 · Block schematic of a PA control loop.

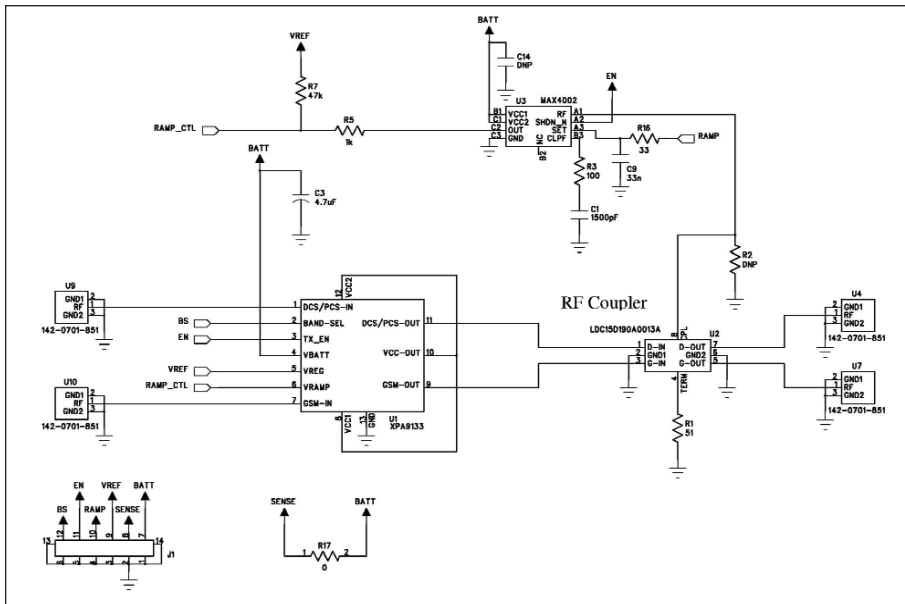

Figure 4 · Implementation of the XIN9133 GSM PA with the MAX4002 power controller.

because the PA is in the forward path of the system. When the loop gain is sufficiently large, the accuracy of the loop depends on the elements in the feedback path, which are the coupler and the detector.

Based on V_{ramp} , the control loop sets the PA's gain control voltage to the level necessary to produce the desired output power level. The detector is connected to a coupler and produces a voltage relative to the measured PA output power. This is compared with V_{ramp} which is generated by the handset baseband chip. The error between V_{ramp} and the measured power is forced to zero by an error amplifier, which sets the V_{supply} of the PA. The closed loop response does not depend on a PA with particularly flat P_{out} vs. temperature or P_{out} vs. V_{CC} .

Implementation of a PA Power Control Loop

The XIN9133 with MAX4002 implementation of PA control circuitry is given in Figure 4. The control loop consists of a limited number of components. Besides the PA and the coupler, all elements of the block diagram of Figure 3 are combined in the PA controller. The PA controller (MAX4002) consists of three blocks:

- RF detector
- Ramp converter
- Error amplifier

Closed Loop Gain Response

This solution is designed to produce a constant output power level. Because the detector has a high dynamic range, the circuit can also be used to precisely set PA output levels

over a wide power range. The MAX4002 has a typical dynamic range of 50 dB. To set a PA output power level, the reference voltage, V_{ramp} , is varied. Non-linearity in the gain transfer function of the PA does not appear in the overall transfer function, P_{out} vs. V_{ramp} . The shape of the curve is determined by the response of the detector. As stated earlier, the elements in the feedback path of the control loop determine the gain transfer function. The detector is the main element in the feedback path. Therefore, the detector needs to be accurate, temperature-stable, and preferably linear in dB to get better performance. The only requirement for the RF coupler control loop is that the gain control function of the PA has to be monotonic. With a linear in dB detector, the relation between V_{ramp} and PA output power is linear in dB as well, which makes calibration of the system straightforward.

Time Mask

GSM mobile phones use a Time Division Multiple Access (TDMA) scheme to transmit data. The TDMA format contains eight time slots. The handset power amplifier typically transmits in one of these time slots. To prevent interference between cell phones, the time mask profile as specified is very restricted. To meet the GSM time mask, the output power of the PA needs to ramp up and down very quickly while staying within the time mask and not generating extraneous frequency bursts due to too abrupt ramp profiles.

As described before, the V_{ramp} input value sets the RF output power. By applying a certain ramp profile to the V_{ramp} pin, the power level (P_{out}) of the PA is set to obtain the required time mask. A time mask of the PA's output power is displayed in Figure 5. The time mask meets the limits (displayed by green lines) over a wide range of temperature, voltage and load variations.

This PA control loop design is a

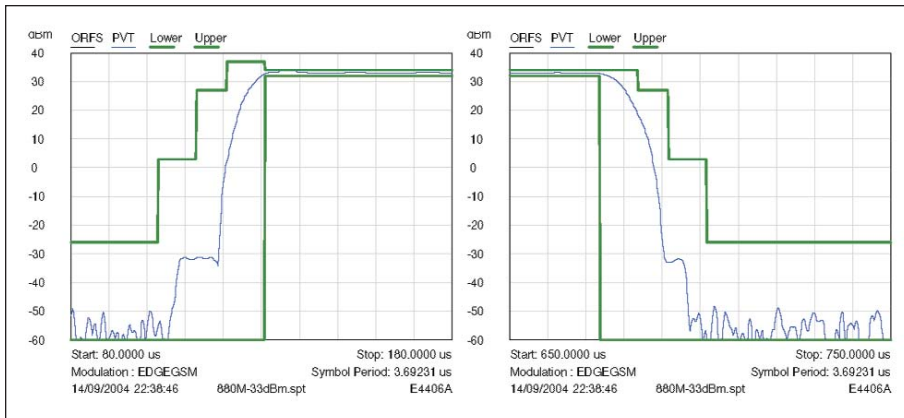

Figure 5 · GSM TDMA time mask (as measured on this design).

powerful tool for controlling the power amplifier’s output to meet the GSM specification. A MAX4002 with the XIN9133 is introduced to solve this design problem. The PA controller has a linear (in dB) response from the DAC of the baseband to the output power of the PA. This is very useful to improve the behavior of the PA. The PA control loop is accurate,

temperature-stable and fast enough to meet the time mask specification. All of the described benefits make the calibration of the PA control loop in production handsets simple and fast.

Reference Design and Evaluation Board

Figure 6 includes a photo of the

reference design and evaluation board available from Xindium Technologies, along with a detailed view of each layer of the four-layer PCB. This layout shows how simple and compact the PA controller layout can be using the XIN9133 and the MAX4002.

Author Information

Paul McCambridge is Vice President, Products, at Xindium Technologies (www.xindium.com). He has more than 20 years of experience in RF and wireless product development, product definition, marketing and business development. His experience in the wireless marketplace spans cellular standards, WLAN, UWB and Bluetooth. He holds a BSEE, MSEE and MBA degree from Santa Clara University.

Brian Whitaker is a Wireless Strategic Applications Engineer at Maxim Integrated Products in Sunnyvale, CA (www.maxim-ic.com).

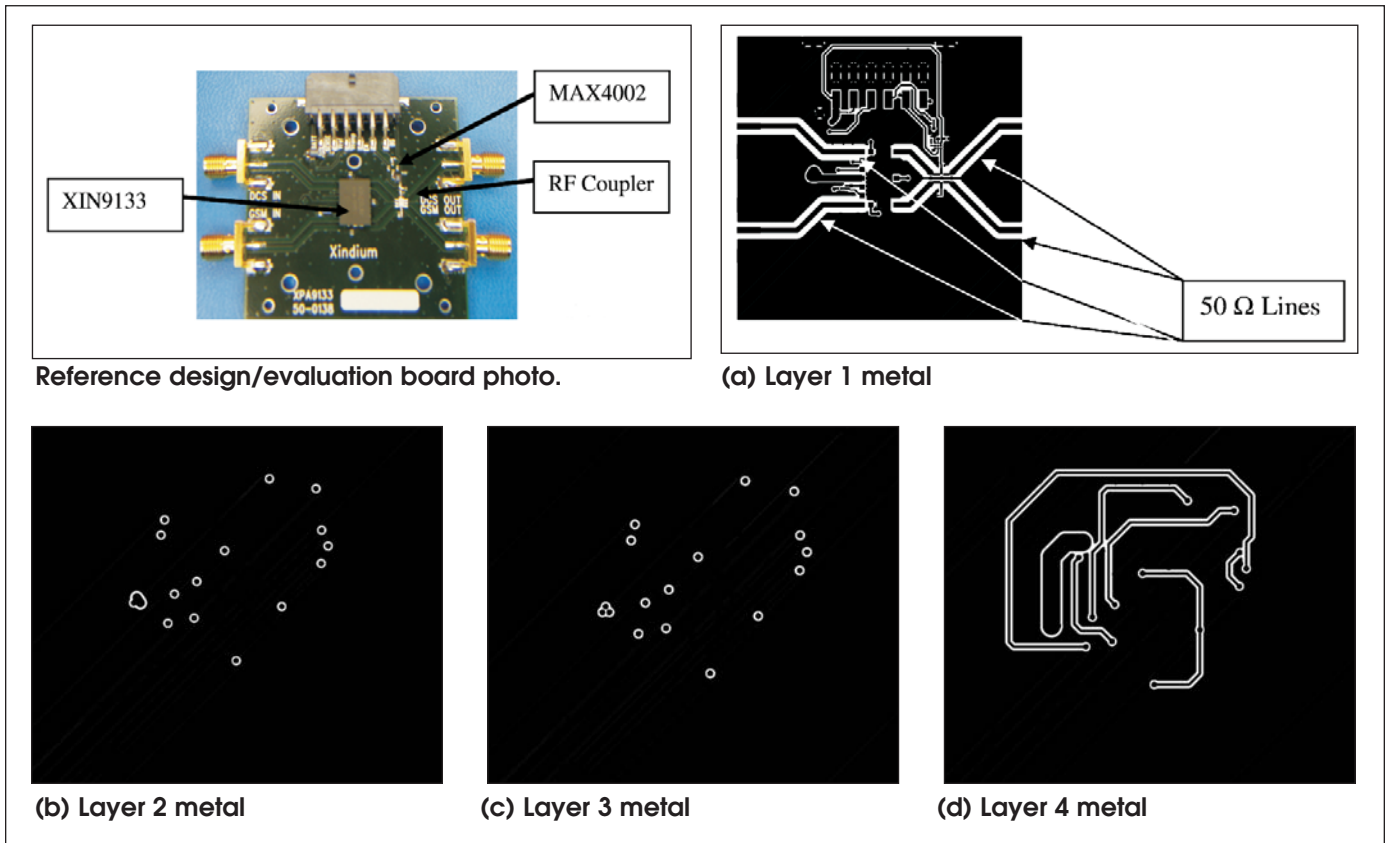

Figure 6 · Layout of the evaluation board.